

## Models

KTC-21    KTC-60    KTC-112

## Features

- High pumping speed at pressures below 10 microns; much lower than attainable with single stage pumps
- Ultimate Vacuum: 0.2 microns (McLeod Gauge)
- Positive pressure lubrication assures operation at any pressure up to atmospheric pressure
- No metal-to-metal contact in pumping chamber
- Unequaled durability, even in dirty applications
- Triplex piston design for quiet, vibration-free operation



## Specifications

	UNIT	MODEL		
		KTC-21	KTC-60	KTC-112
Nominal Displacement at Rated RPM	CFM / <i>m³/h</i>	21 / <b>36</b>	60 / <b>102</b>	107 / <b>182</b>
Motor	HP / <i>kW</i>	1.5 / <b>1.1</b>	3 / <b>2.2</b>	7.5 / <b>5.6</b>
Motor Speed	RPM	1725	960	1060
Cooling Water Required	GPM / <i>L/min</i>	—	—	1.5 / <b>5.7</b>
Oil Capacity	Quarts / <i>Liters</i>	2.0 / <b>1.9</b>	8.0 / <b>7.6</b>	16.0 / <b>15.1</b>
Pump Weight	Lbs. / <i>kg</i>	190 / <b>86</b>	515 / <b>234</b>	880 / <b>399</b>
Maximum Gas Ballast Flow	%	10	10	10
Gas Ballast Pressure	Torr (mm Hg abs.)	.020	.020	.020
Ultimate Pressure	Microns	.2	.2	.2
Noise Level at 0.1 Torr	dB(A)	72	70	70

## Typical Pumping Speed Curves

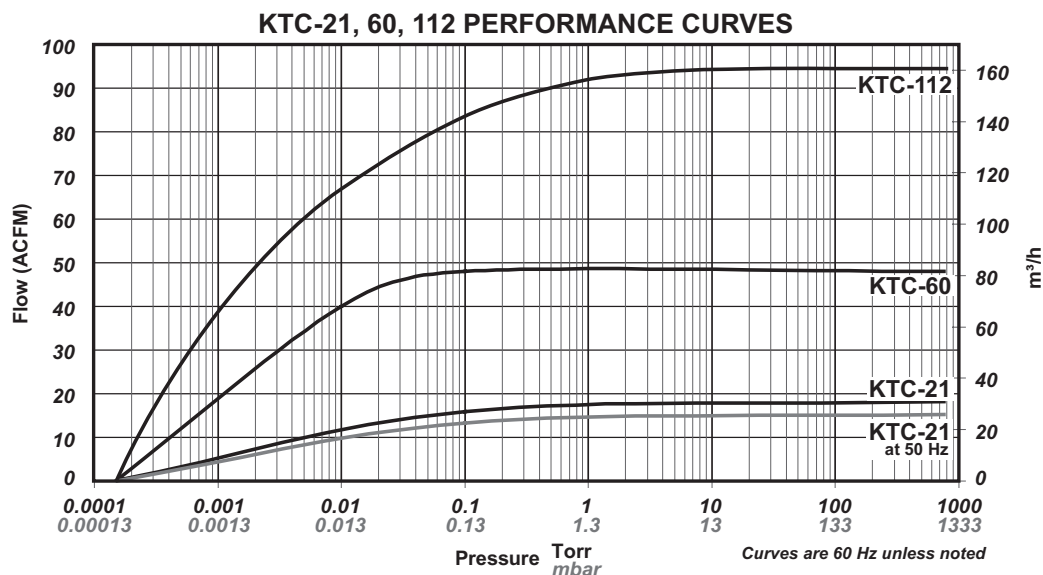

## Dimensions

Values shown are approximate and should not be used for construction.  
 Certified drawings are available through your local Tuthill Vacuum & Blower Systems Sales Professional.

### Models KTC-21

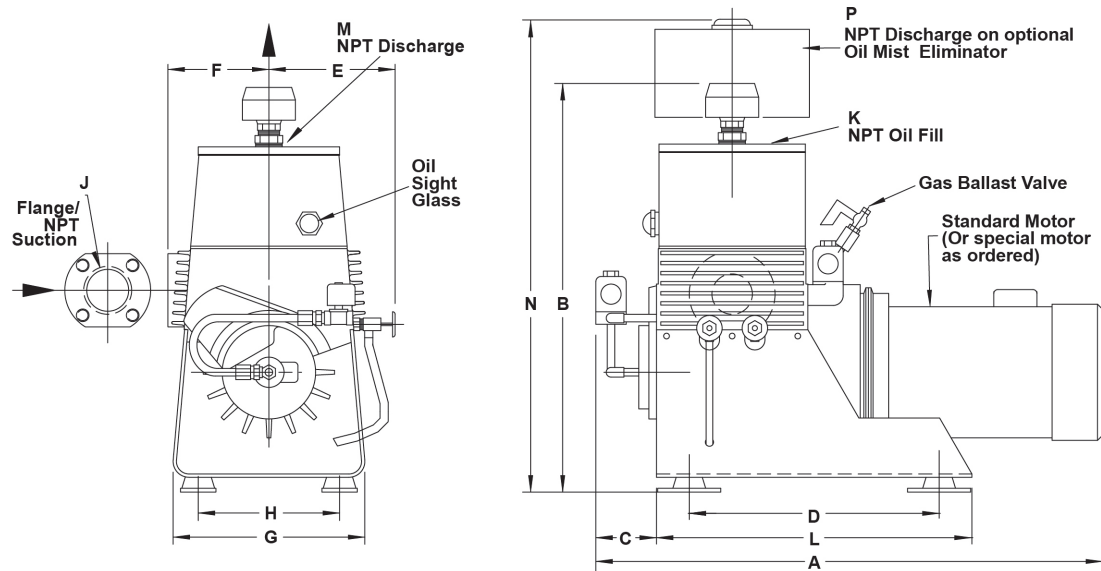

in. mm	A	B	C	D	E	F	G	H	J	K	L	M	N	P	Weight lbs / kg
KTC-21	25.13 638	20.25 515	3.00 76	12.38 314	6.25 159	5 127	9.5 241	7 175	1 1/4" FLG 2" NPT	1" NPT	15.63 397	3/4" NPT	23.44 595	1 1/2" NPT	190 86

### Models KTC-30, KTC-112

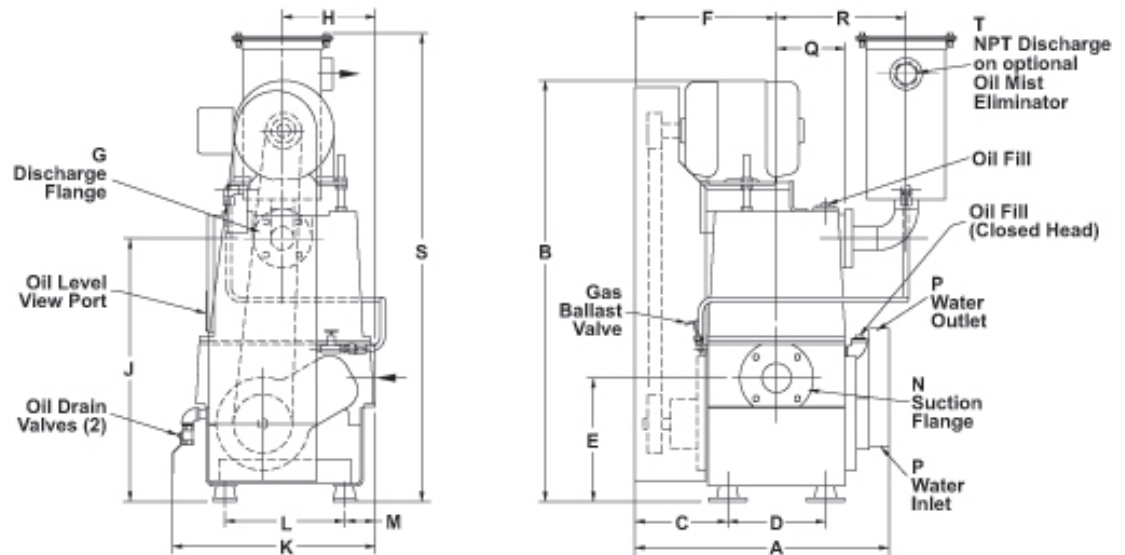

in. mm	A	B	C	D	E	F	G	H	J	K	L	M	N	P	Q	R	S	T	Weight lbs / kg
KTC-60	23.69 602	36.50 927	8.19 208	10 254	19.63 498	13.19 335	1 1/4" FLG	8 203	21.44 545	19.7 500	11.50 292	2.25 57	3" FLG	—	6.19 157	11.50 292	38.44 976	1 1/2" NPT	515 234
KTC-112	26 660	44.25 1124	9.5 241	10 254	14 356	14.50 368	2" FLG	9.50 241	28.25 718	20.75 527	12.25 311	3.13 79	3" FLG	1/4" NPT	7.25 184	13.25 337	48.88 1242	2" NPT	880 399

Your Local Tuthill Vacuum Blower Systems Sales Professional:



Tuthill Vacuum & Blower Systems  
 4840 West Kearney Street  
 Springfield, Missouri USA 65803-8702  
 o 417.865.8715 800.825.6937 f 417.865.2950  
[tuthillvacuumblower.com](http://tuthillvacuumblower.com)

